

STL2 SERIES OUTDOOR LIGHTING

STL2-200W-50K-480V

WESTGATE
THE FUTURE IS HERE...AND IT'S QUITE BRIGHT!



Selection:



This outdoor lighting is ideal for general site lighting, street, roadway, alleys, loading docks, doorway, pathway, and parking areas

Customer Name: _____

Project Name: _____

Note: _____

Type: _____

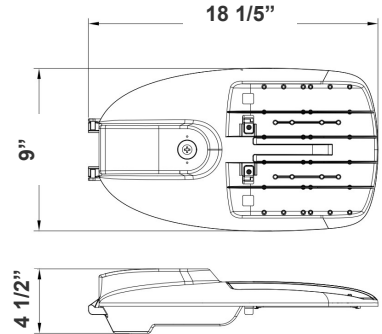

21 4/5"(L) x 12 1/4"(W) x 4 4/5"(H)

Features

- Light Grey Finish
- With NEMA twist-lock Photocell Socket (Shorting Cap included)
- 7-Year Warranty
- Outdoor Light

Technical Specifications

Electrical:

- Voltage: 480V
- Power Factor: >0.95
- Wattage: 200W
- Efficacy: 135 LPW

Mechanical:

- Die-cast Aluminum with Powder Coat Finish (Light Grey)
- Cord Type: 40" SJTW 18/3 AWG Cable
- With 2-15/16" Diameter Pole Entry with Adapter Bracket Inside for Smaller Pole Diameters
- Maximum Ambient Temperature: 104°F
- Rated life: 70,000 hrs
- Wet Location
- IP Rating: IP65

Lighting:

- Lens Type: Optical TYPE III Lens, High Light Transmittance PC, Anti-UV and Flame Resistant
- Dimming: 0-10 Dimming
- Driver Located in Isolated Compartment for Improved Thermal Management
- Total Lumens: 27000LM
- Color Temperatures: 5000K
- Color Rendering Index: CRI ≥ 80

Applications:

- Ideal for general site lighting, street, roadway, alleys, loading docks, doorway, pathway and parking areas

Other Models:

- 90W | 13500LM | STL2-90W-50K-480V
- 150W | 21000LM | STL2-150W-50K-480V



Phone: (877) 805-2252 | Fax: (877) 805-2252
www.westgatemfg.com | www.westgatecontrols.co



WG-Z7-2D-2Z

Photometrics: STL2-200W-480V

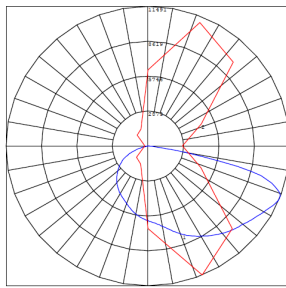
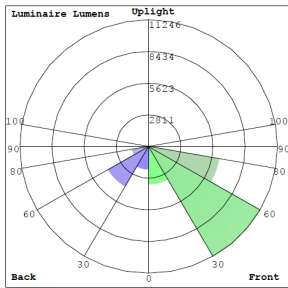

BUG Rating: B3-U0-G3

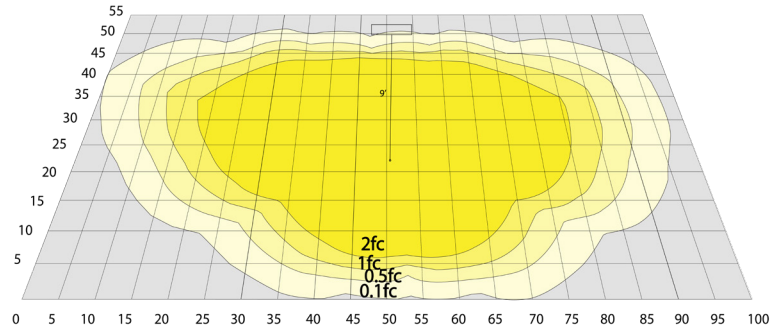

Area 55'x 100' Mounting Height: 9'

Other Views:



Side View



Front View



Back View



Mounting Hole View

Performance Table: STL2-200W-480V

MODEL NO.	Wattage	Voltage	Lumens	Color Temp.	BUG Rating	LPW
STL2-200W-50K-480V	200W	480V	13500LM	5000K	B3-U0-G3	135

Sample Ordering

Model	Watt	Color Temp.	Voltage
STL2	200W	50K = 5000K	480V

Accessories:

Blank = No Option For Accessories

STL2-WMA = WALL MOUNTING ARM 12 3/4" LENGTH

PC-TWIST = 1800W TUNGSTEN TWIST LOCK PHOTOCELL

Example:

- STL2-200W-50K-480V (FOR STL2 200W 5000K OUTDOOR LIGHT FIXTURE 480V)
- STL2-200W-50K-480V STL2-WMA (FOR STL2 200W 5000K OUTDOOR LIGHT FIXTURE 480V)
(FOR WALL MOUNTING ARM 12 3/4" LENGTH)

ACCESSORIES:



STL2-WMA
WALL MOUNTING ARM
12 3/4" LENGTH



PC-TWIST
1800W TUNGSTEN TWIST LOCK
PHOTOCELL